

HEATSTRIP[®]



TT-MTM2 Product & Installation Manual



TT-MTM2 Hard– Wired Controller with Remote



TT-MTM2 Wall Controller

This controller is a custom designed and manufactured controller for HEATSTRIP heaters. It has been designed for ease of use and to provide low running costs of your heater. It provides both temperature control (allowing the user to turn the heat output up or down depending on the ambient temperature and conditions) and a timer for automatic heater shut-off operation.

The timer function has 4 settings: 1 hour, 2 hours, 4 hours or constantly on. This feature is ideal for applications such as BBQ areas, alfresco areas, restaurant dining, assembly line production etc. When continuous heat is not required. The timer also reduces the likelihood of heaters being inadvertently left turned on.

Depending on the ambient temperature there may be a requirement to control the heat output of the heater. The controller has 3 settings, they are High, Medium and Low.

The controller allows a combination of the multiple timer (1/2/4 hour) and heat outputs (High/Medium/Low)

Controlling multiple heaters

It is possible to use one wall controller to control multiple heaters. The wall controller is rated at 16 Amps and 240 volts.

Remote Pairing

All units operate using the same remote control frequency, therefore, multiple wall controllers can be operated using a single remote control.

The remote will function at distances of **over 8m when used in a straight line**, This distance reduces when used at an angle.



MODEL	MAXIMUM VOLTAGE (Volts)	MAXIMUM CURRENT (Amps)	PACKAGED DIMENSIONS (mm)	UNIT WEIGHT (kg)
TT-MTM2	240	16	150 x 95 x 55	0.3



Operation

Press “On/Off” button to turn power on and off.

Once turned on, the controller will default to High power setting and will be permanently on (no timer function). Press “POWER” button to select the desired power setting by cycling through HIGH—MEDIUM—LOW. When power setting is at high the controller will provide continuous power. When power setting is at “MEDIUM” or “LOW” the output alternates between being on and off so that it delivers a lower output to the heater. Press “TIMER” button to set the timer to 1,2,4 hours or permanently on. When permanently on, one of the TIMER LED’s will be illuminated. Once the timer is selected, the timer will be started immediately. When the timer has ended, power will turn off and all LED’s will also turn off.

Thermal Cut-Out Protection

This controller is protected by a thermal cut-out switch. This switch is activated when the temperature of the controller is too high. The controller will cut all power until it has sufficiently cooled. Once it cools the unit will continue working as usual.

Warm Up Mode

The controller is programmed to operate continuously (High setting) for the first 15 minutes of operation regarding less of the selected power setting, this is to allow time for the heater to warm up. After this time it will operate as selected.

Safety

The TT-MTM controller is to be mounted indoors it needs to be away from wet conditions. Ensure the connections are properly connected. The controller needs to be installed according to your local wiring guidelines and regulations . Do not allow any cables, furnishings, flammable materials or other items to obstruct the vents of the controller. Never block the air vents of the controller.

Never block the air vents of the controller. Do not put anything in the vents of the controller.

The appliance is not intended for use by persons (Including children) with reduced physical, sensory or intellectual capabilities, or lack of experience and knowledge , unless they have been given supervision or instruction concerning use of the appliance by person responsible for their safety. Children should be supervised to ensure they do not play with the appliance.

Maintenance

The TT-MTM Controller is made from durable materials, however regular care and maintenance of your controller will help prolong the life of the product. It is recommended that you dust the controller to keep the surface clean. Cleaning at least every three months will reduce the amount of dust build up and keep it looking at its best. Do not use any abrasive materials or products to clean the controller, this includes solvents, citrus based cleaners or other harsh cleaning products. Do not use water or a damp cloth to clean the controller. The remote uses a CR2025 3V lithium battery. If the red light on the remote stops working then change the battery.



TT-MTM2 Controller Installation Guide

Controller Wiring Example

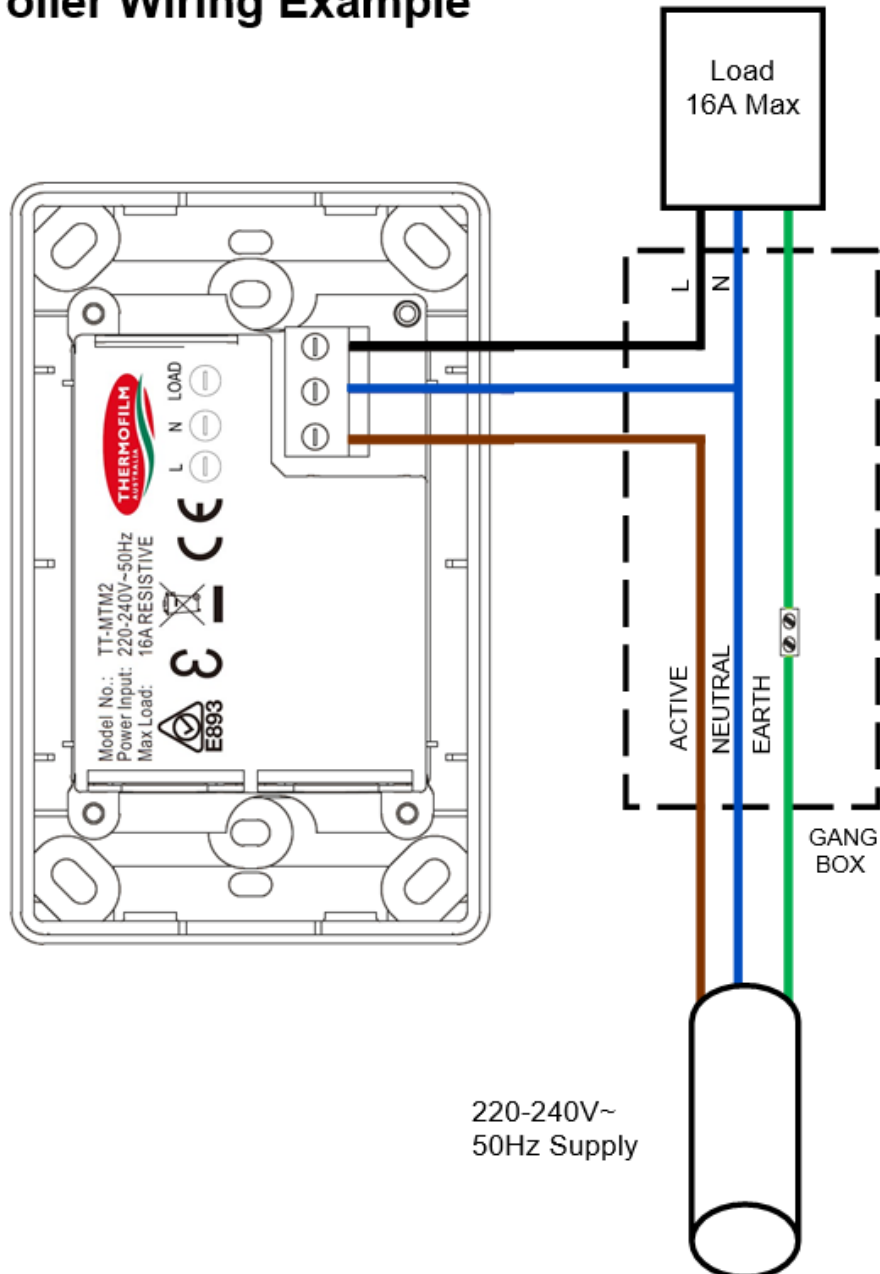

The TT-MTM2 Controller requires sufficient air circulation in order to provide continuous operation on the high power load setting. The vents must always remain clear; never block or cover the vents.

An ideal controller installation will provide significant space around the back of the controller. Installing into restricted spaces, such as brick walls, may result in overheating if adequate ventilation is not provided.



Heater wiring schematic diagrams

It is recommended to install an ON/OFF isolation switch before the controller and ensure the unit is turned OFF after use.

Multiple heaters can be operated using a single controller, however the maximum current rating of 16A must not be exceeded. For direct wiring to the controller, the maximum is generally on heater unit unless the combined maximum current is less than 16A. For example, 2x THH1800A can be connected directly to the controller.

Below are example circuits indicating potential installation configurations.

Always check with your electrician and ensure all wiring is in accordance with local regulations.

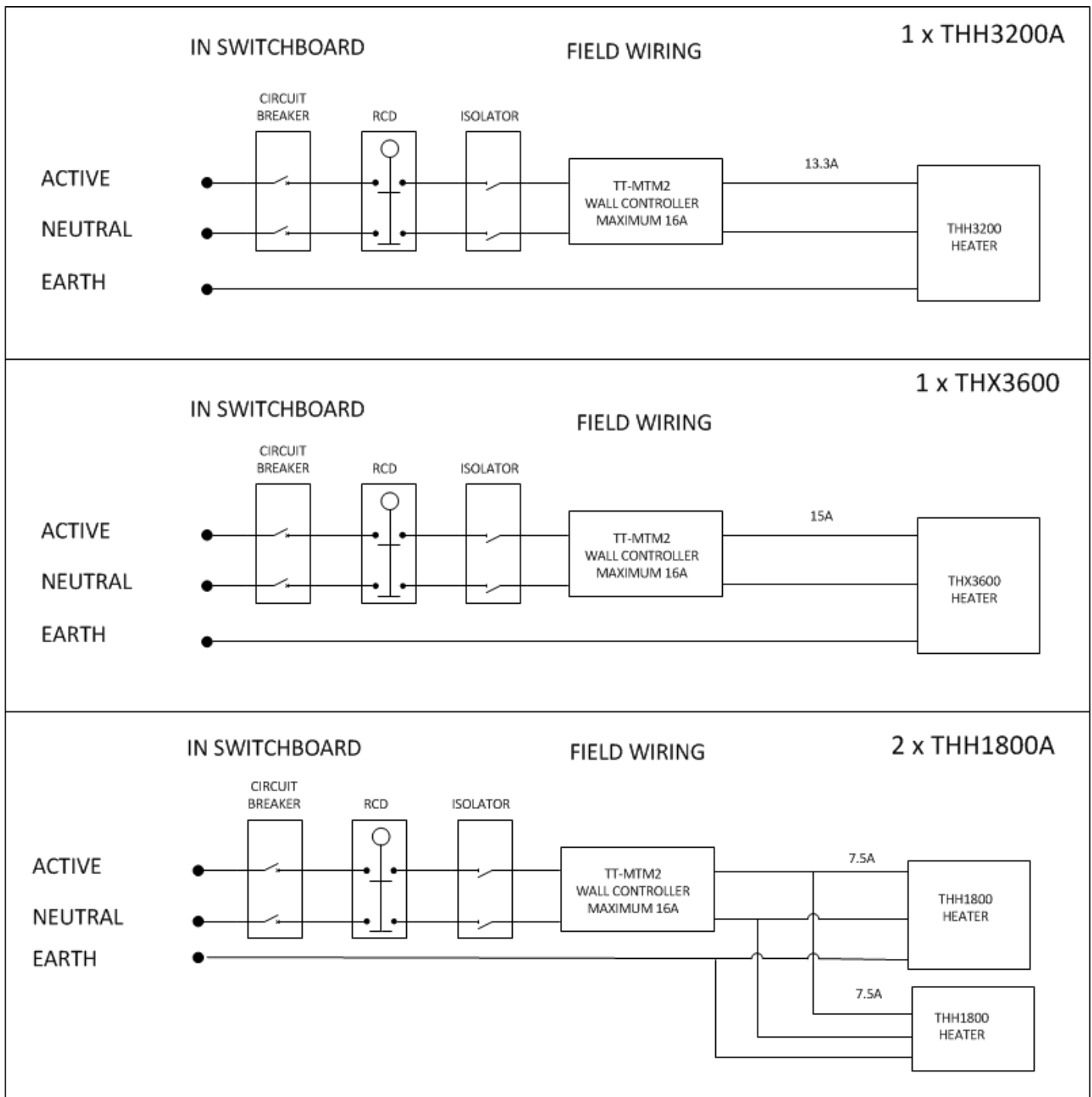



Warranty Terms & Conditions

The below Warranty Terms and Conditions apply for **New Zealand and Australia only**. For international warranty please refer to international warranty terms and conditions.

Thermofilm warrants to the original owner that TT-MTM2 Wall Controller products will be free from defects in materials and workmanship for a period of 12 months from the date of purchase in accordance with the following warranty terms and conditions.

Provision of this warranty is subject to:

- The TT-MTM2 Wall Controller product must be installed in accordance with the Installation Instructions and relevant electrical standards and codes.
- The TT-MTM2 Wall Controller product must be maintained and cleaned according to instructions detailed in the Installation Manual.
- There is no warranty expressed or implied with regard to capacity requirements. The selection of the unit or units depends entirely upon the system design and capabilities as determined by the purchaser.
- This customer has not repaired, opened or altered the product in any unauthorised manner.
- This warranty excludes damage to the product or components arising from circumstances outside the control of Thermofilm, including, but not limited to, where the product is not used for intended purpose; where the product has been rectified in any way; incorrect installation; incorrect power supply; damaged caused during delivery; misapplication, misuse, abuse, vandalism, lack of maintenance or accident.
- Thermofilm's obligations under the warranty are limited to repair or replacement at Thermofilm's factory of any components of the product which Thermofilm identifies to its satisfaction to be defective.
- Transportation charges involved in return of the product to the Thermofilm factory (or any other location authorised in writing by Thermofilm) is the sole responsibility of the customer.
- All products or components will be supplied in advance of an examination of the faulty product or components by Thermofilm or an authorized representative of Thermofilm.
- All products or components will be supplied in advance of an examination of the faulty product or components by Thermofilm factory, if not delivered by Thermofilm to destination.
- No products or components will be supplied in advance of examination of the faulty product or components by Thermofilm or an authorised representative of Thermofilm.
- Thermofilm does not participate in any site related costs or labour expenses incidental to replace of parts, repairing, removing, installing, servicing, transportation or handling of parts to complete products, and assumes no liability on parts repaired or replaced without written authorisation. Thermofilm shall not be liable for any default or delay in performance of its warranty obligations caused by any circumstance beyond its control, including, but not limited to, judicial or government restrictions, strikes, fires, floods, abnormal weather conditions, delayed supply of components.

Should products be determined as damaged on arrival, immediately notify the transport company of the condition and have them noted on the freight documents. If damage is discovered after unpacking, demand immediate inspection by the transportation company and insist that a record of the damage is made on the freight documentation.

The customer warrants using the product in accordance with:

- Any instructions provided to it by Thermofilm from time to time.
- All government and local regulations, including but not limited to all relevant electrical, environmental laws and regulations governing the installation, storage, use, handling and maintenance of the goods.
- All necessary and appropriate precautions and safety measures relating to the installation, storage, use, handling and maintenance of goods.

Our goods come with guarantees that cannot be excluded under the Australian Consumer Law. You are entitled to a replacement or refund for a major failure and for compensation for any other reasonably foreseeable loss or damage. You are also entitled to have the goods repaired or replaced if the goods fail to be of acceptable quality and the failure does not amount to a major failure.

All warranty requests for repairs or repairs or replacements must be accompanied by a complete "Warranty Claim Form" available from Thermofilm, together with proof of purchase (and where possible, photos of the installation) and the heater returned to the place of purchase.

In the event of a warranty claim, the goods need to be returned to the distributor/retailer for repair/replacement. Contact

D.R. Distribution Pty. Ltd.

Phone 02 9618 3842

9/3 Lancaster St Ingleburn NSW 2565

www.drdistribution.com.au

