



**UNIDARE
VFMi40A & VFMi60A
INSTALLATION MANUAL**

Contents

Operating instructions for the user	2-3
Delivery conditions	4
Minimum clearances	4
Assembly	5-9
Circuit diagram	8
Resetting the thermal cutout	9
Commissioning	10
Technical information	10

Operating instructions

General notes

Page	2-3
	4
	4
	5-9
	8
	9
	10
	10

Please take good care of these operating instructions, and in event of there being a change of ownership of the appliance, pass them on to the next owner. The user instructions must always be available and when an electrician is working on the appliance they must be given to him for reference.

The installation and repair of the appliances may only be carried out by qualified personnel. Repairs which are not properly undertaken can lead to considerable damage.

Attention! Important

During operation the temperature rise of the heater surface may exceed 80 °C.

Covering the heater will lead to higher than normal operating temperature at the surface and may result in the covering material being scorched.

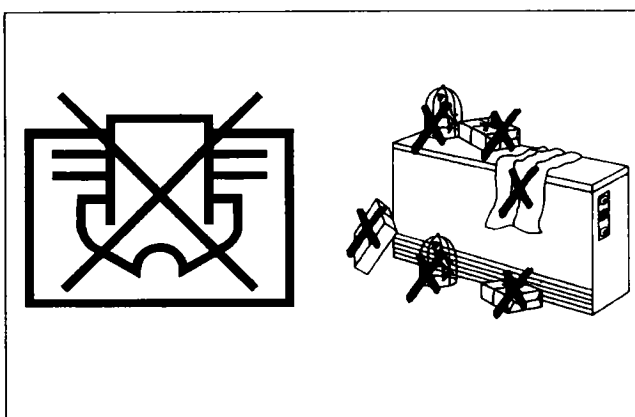

It is imperative to ensure that combustible or flammable materials such as curtains, paper, aerosol cans, etc., are not placed next to, in front of or on top of the heater, and do not lie in the direct path of the warm air current from the fan.

Never use a steam cleaner to clean the storage heater.

Function

The storage heater operates by storing up in the core material at night the heat required during the day. In this way the heater consumes inexpensive electricity energy during the period when the electric distribution networks are not fully utilised.

Note

The temperature at the heater surface is only a rough measure of the heat content of the appliance. This is especially so of heaters with differing power ratings.

Occasionally during operation a cracking sound may be heard from the heater. This arises because of the changing temperature of the heaters core material.

The first charging cycle

As with all new appliances, during the first usage there may be an odour. Please allow adequate ventilation for this possibility.

Manuel charging

If the charging of the heater is to be controlled manually the control knob should be pushed fully onto the shaft of the charge controller. To do this the plastic cap on the top right side of the heater must first be removed.

The amount of heater to be stored is changed by turning the knob.

General rule: On very cold days a high amount of charge is required (turn knob all the way to the right). If the outside temperature is higher then choose a lower setting.

Setting changes should only be made in small steps.

When the knob is turned all the way to the left the heater does not charge up at all. The delivery of the stored heat from the storage heater for room heating purposes is automatically controlled by the room thermostat.

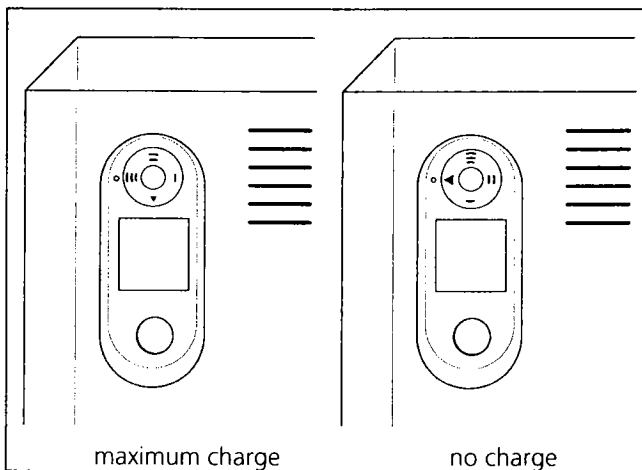

Maintenance

The storage heater requires very little maintenance. It is however recommended that, before the start of the second heating season, the ventilator inlet and outlet compartments be cleaned by qualified personnel. Hereafter the maintenance intervals can be decided on an individual basis.

What to do in case of a fault

If the heater develops a fault, please pay attention to the directions here. If you cannot find the cause of the fault, please call your nearest service office or authorised workshop. In such cases please give the service number of your unit and as exact a description as possible of the fault. You will find the service number (E-Nr. and FD) of the appliance on the rating label on the right hand side of the appliance underneath the air outlet grill.

Rating label

	3/N/PE-400V 50/60Hz		1/N/PE-230V 50/60Hz	Art.nr.: 327 930
	8 h		15 W	
Made in Germany	3,0 kW 24 kWh MFI 330 2NG3 330			E-Nr.: 46/2531 FD:

Service number

Eliminating small faults yourself

1. The room is not warm enough

- Check the fuses/circuit breakers for the storage heaters in the fuse box and if necessary change them or switch them on. If the fuses blow or circuit breakers trip again call your service man.
- The charge controller intensity of the storage heater is turned down too low. Adjust the setting.
- The room thermostat is not properly set. If necessary adjust the setting.
- The fan in the storage heater is not working. Check the fuse/circuit breaker in the fuse box and if necessary change or reset it. If the fuse blows, or circuit breaker trips again call your service man.
- The doors and windows are always open, or the adjoining rooms are not heated although the system was dimensioned to include the heating of neighbouring rooms. There is no fault in the appliance or the control.

2. The room is too warm

- The room thermostat is not properly set. If necessary adjust the setting.
- The charge controller is not properly set. If necessary adjust the setting.

Before you call the service man please first try to eliminate the fault yourself using the hints outlined above.

Installation instructions

Delivery conditions

The heating elements for the storage heaters are not installed in the factory. Special sets of heating elements are delivered separately (see table on page 10).

The heating element set contains:

- the elements
- the knob for the charge controller
- the accessories for tip-over protection
- the fixing screws for the wall mounting spacer

All wall mounting spacers are contained in the cardboard package on top of the polystyrene packing.

The storage bricks are separately packed and delivered as a complete set.

Transport damage should be reported immediately to the carrier. Minor damage to core bricks does not significantly affect the operation of the heater.

Erection

The installation and connection of the unit may only be carried out by qualified personnel who are licensed to undertake such installations by your local electricity supply company.

The erection site must be flat and even and the bearing strength of the floor should be capable of taking the weight of the storage heater, (see table on page 10). The units can be erected on any conventional floor, although changes can occur in floor covering at the foot of the heater because of its weight and the heat it generates where it is in contact with PVC, parquet flooring, or soft or light-coloured carpeting.

If there is any skirting board or carpet in contact with the back of the heater it must be removed before using the unit.

Underlay slabs or wall mountings should be used if it is expected that the feet of the unit will sink into the floor covering thus preventing convection underneath the storage heater. In the case of deep-pile carpets underlay slabs or a floor podium unit **must** be used.

The minimum clearances must be strictly observed and may under no circumstances be reduced.

Minimum Clearances

The distance between the storage heater sides, top, and other things in the room, like, e. g. window recesses and cupboard walls must be at least 100 mm. If two storage heaters are erected beside one another, the minimum distance between them must be 100 mm. The air outlet grill must have at least 300 mm clearance, i. e. nothing may interfere with the air outlet within a 300 mm distance and this includes floor mats.

Warning!

Electric storage heaters may not be operated:

- in areas where explosive gas may be present,
- in areas where corrosive air is to be expected, e. g. dry cleaners, hair dressing salons, etc.

Important

Installers of storage heaters in industrial or public areas such as hotels, holiday apartments, schools, administration buildings, and the like, must ensure that the enclosed warning symbol „Do not cover or obstruct the heater“, is stuck in an easily seen position on the units housing.

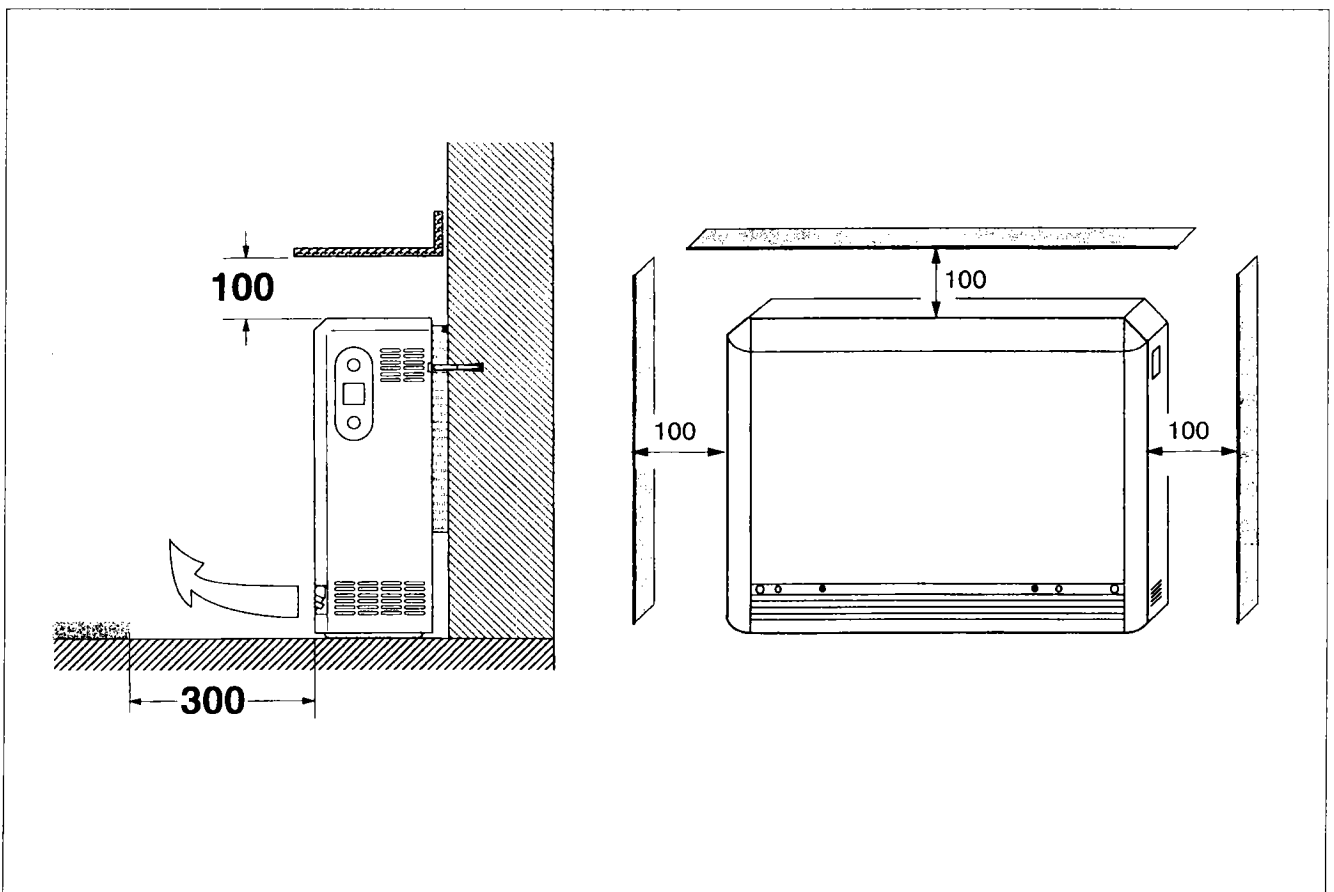

Unit assembly

Important: The heater may only be installed and repaired by skilled persons.

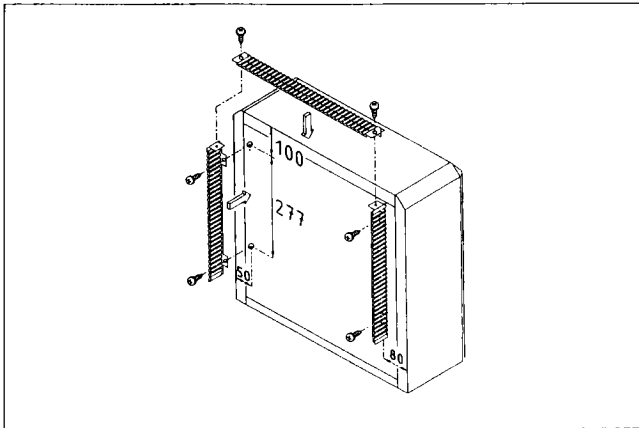

1. Take the heater out of its packaging. Dispose of the packing material in an appropriate way. Screw the two side wall contact strips onto the rear wall of the heater. Screw the upper wall contact strip onto the two wall contact strips on the sides.

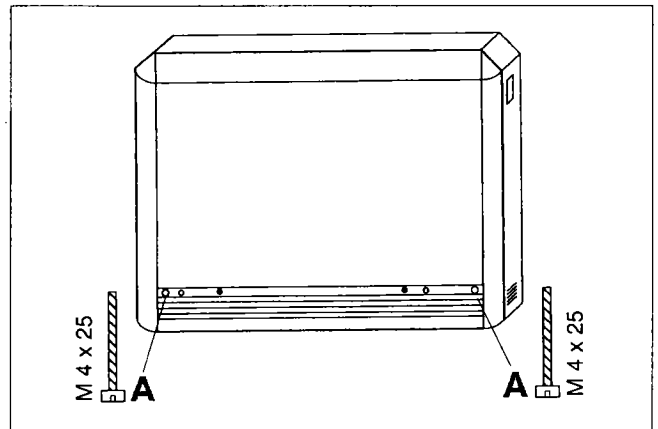

2. Remove the fastening screws for the two side walls.

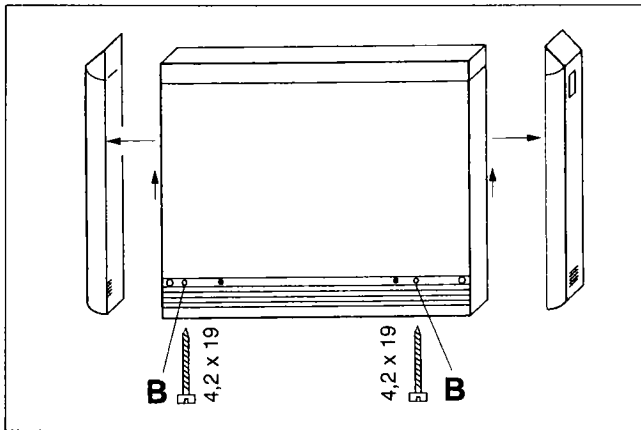

3. Push the left-hand and right-hand side walls vertically about 5 mm upwards and then pull off horizontally. Undo the fastening screws for the front wall.

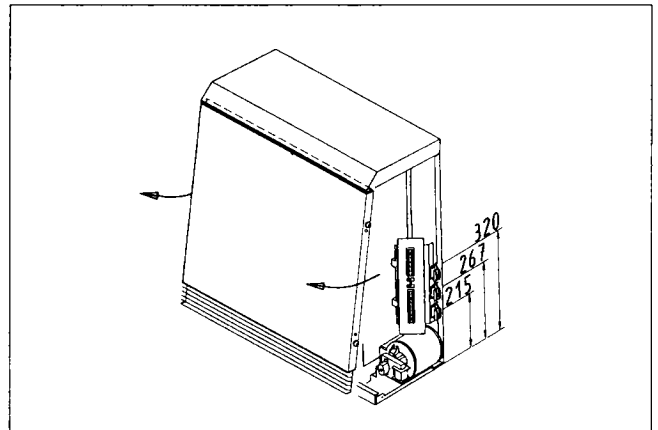

4. Swing the front wall forwards and remove it from the upper edge. Insert the connecting cables and strain-relieve (see also electrical connection page 8). The connecting leads should be cut to a suitable length so that they cannot come into contact with any hot surfaces of the heater. No loops of cable should be left behind or underneath the unit.

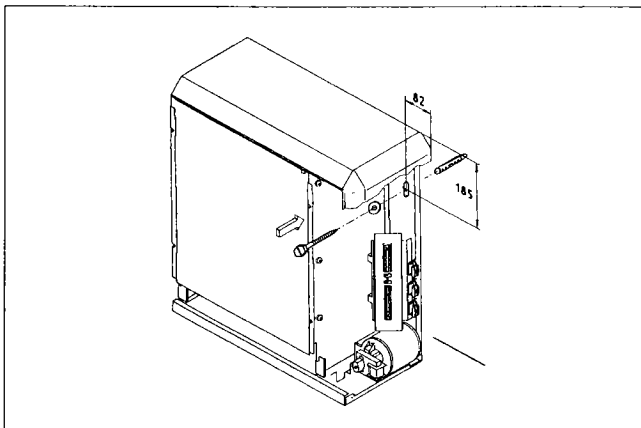

5. **Stability**
In the case of a fixed connection to the mains supply (without wall box), all types of heater must be secured against toppling over.

The heater types VFMi 20 und VFMi 30 must be secured against toppling even if a wall box is used. The finally assembled heater must be able to resist a horizontal pull of at least 200N on its upper edge without toppling or shifting. If the required stability cannot be achieved with the supplied accessories, e.g. in the case of light-construction walls, the installer must select a suitable wall fixing method. It is recommended to secure all heaters against toppling, regardless of their size and type of connection.

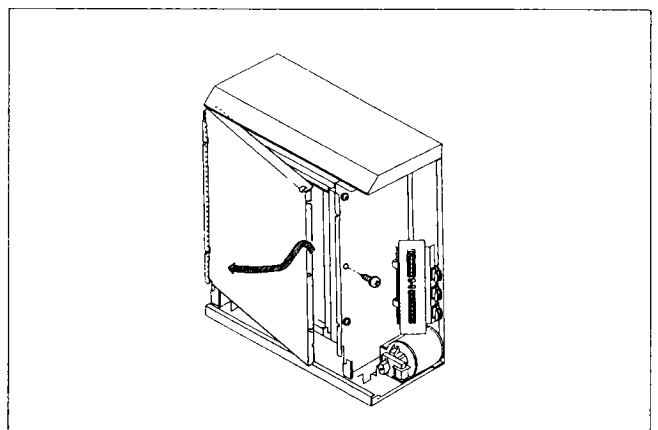

6. Remove core space cover. For this purpose, unscrew the middle fastening screw, swing the core space cover out slightly on the right-hand side and pull it to the right. Lay the cover down in such a way as not to damage the thermal insulation.

Unit assembly

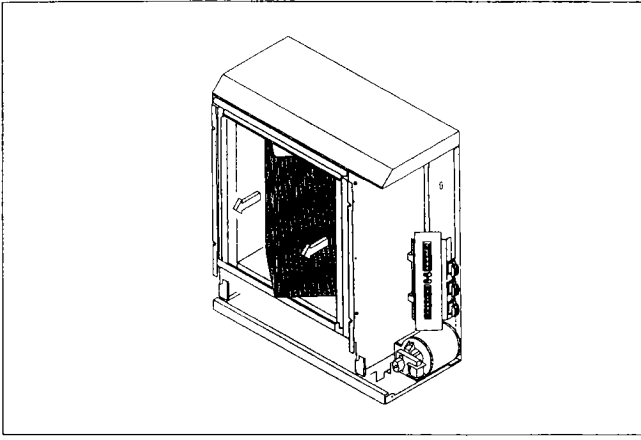

7. Remove the transport protection (folded cardboard).

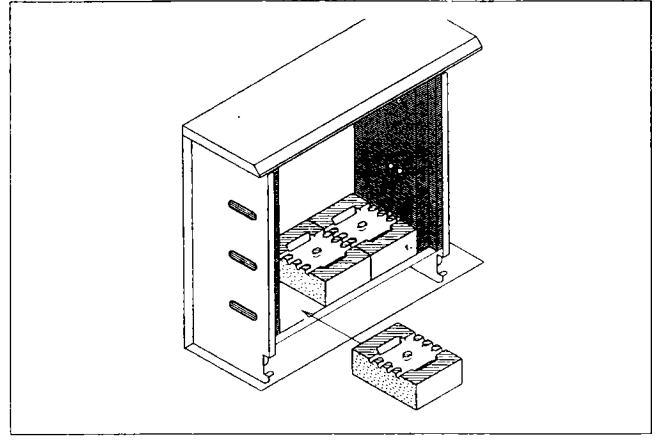

8. Put in the lower row of storage bricks. Begin at the right-hand side.

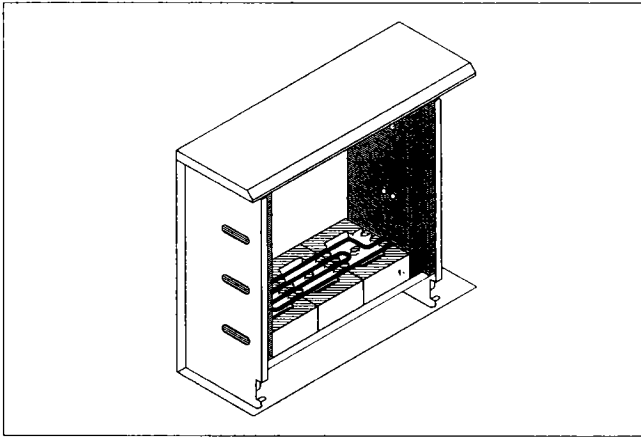

9. After putting in the lower row of bricks, install the first radiator.

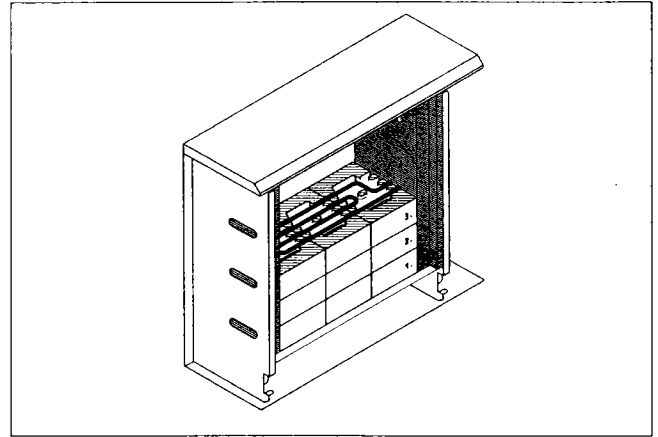

10. Put in the second and third rows of bricks. Install second radiator.

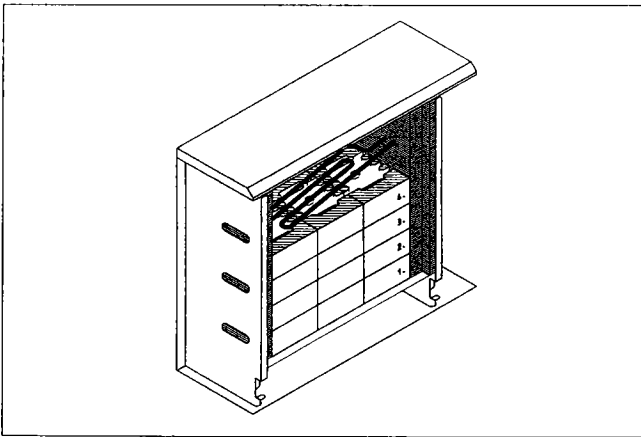

11. After putting in the fourth row of bricks, install the third radiator. Push the fifth row of bricks sideways under the third radiator.

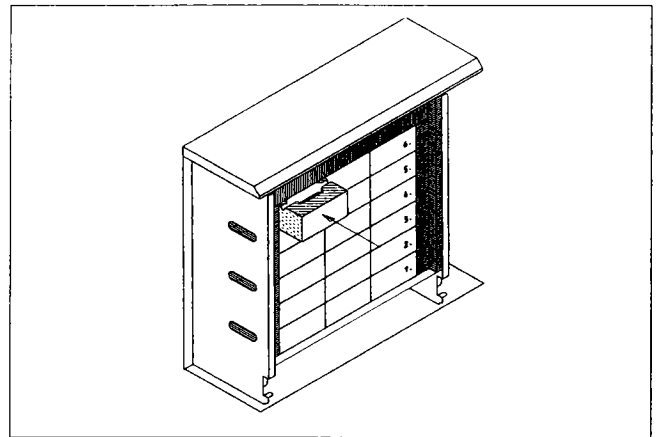

12. Put in the last row of bricks (6 rows of bricks in all). Clean the air outlet space and the switching space.

Unit assembly

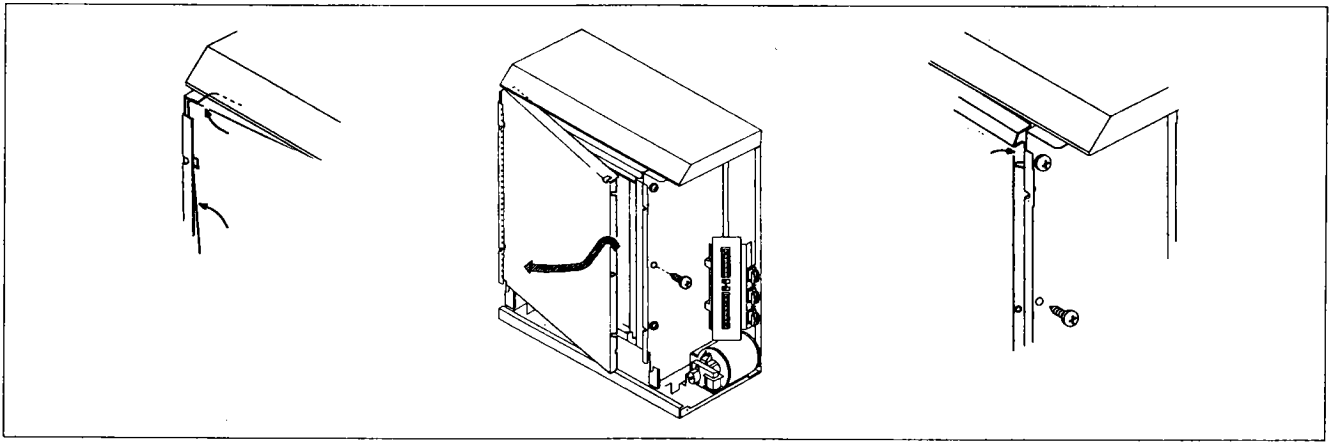

13. Insert core space cover.

Left-hand side:

The lip at the top of the core space cover must lie on the left-hand partition.

The side edge of the core space cover must be pushed behind the lip of the left-hand partition.

Right-hand side:

Insert side flange of the core space cover between the thermal insulation and the partition, paying attention to the guide slots. Tightly press the core space cover and screw it tightly to the right-hand partition.

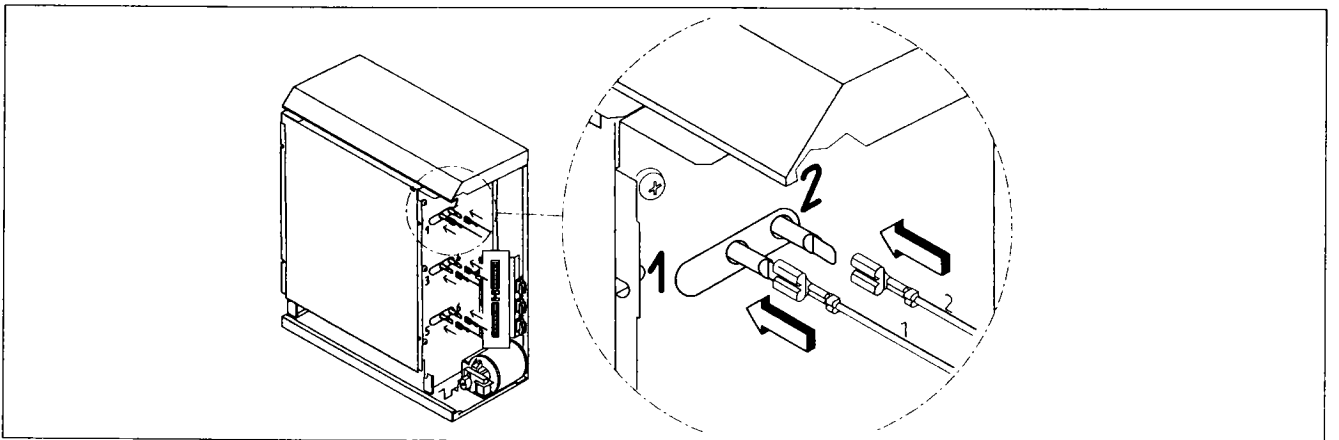

14. Connect the radiators.

For this purpose, place the numbered connecting cables on the connection ends of the radiators. The partition is also marked with the corresponding numbers. Fasten loose cables to the cable harness.

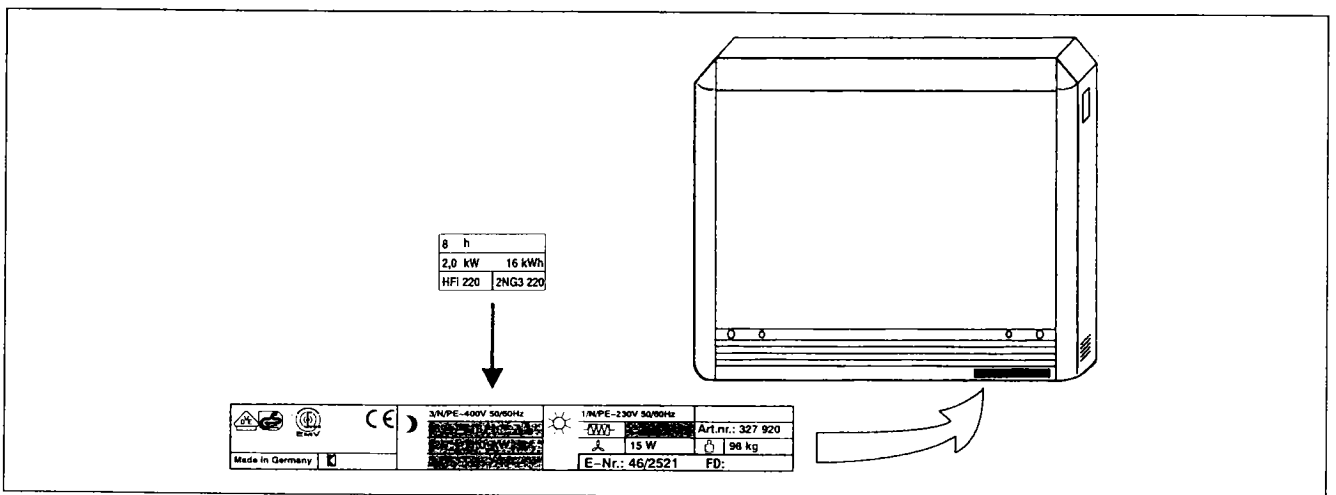

15. Stick the rating plate of the radiator set on the heater nameplate.



weight



charge acceptance



control part



auxiliary heating



fan

Electrical connection

Connection with wall-mounted room temperature controller

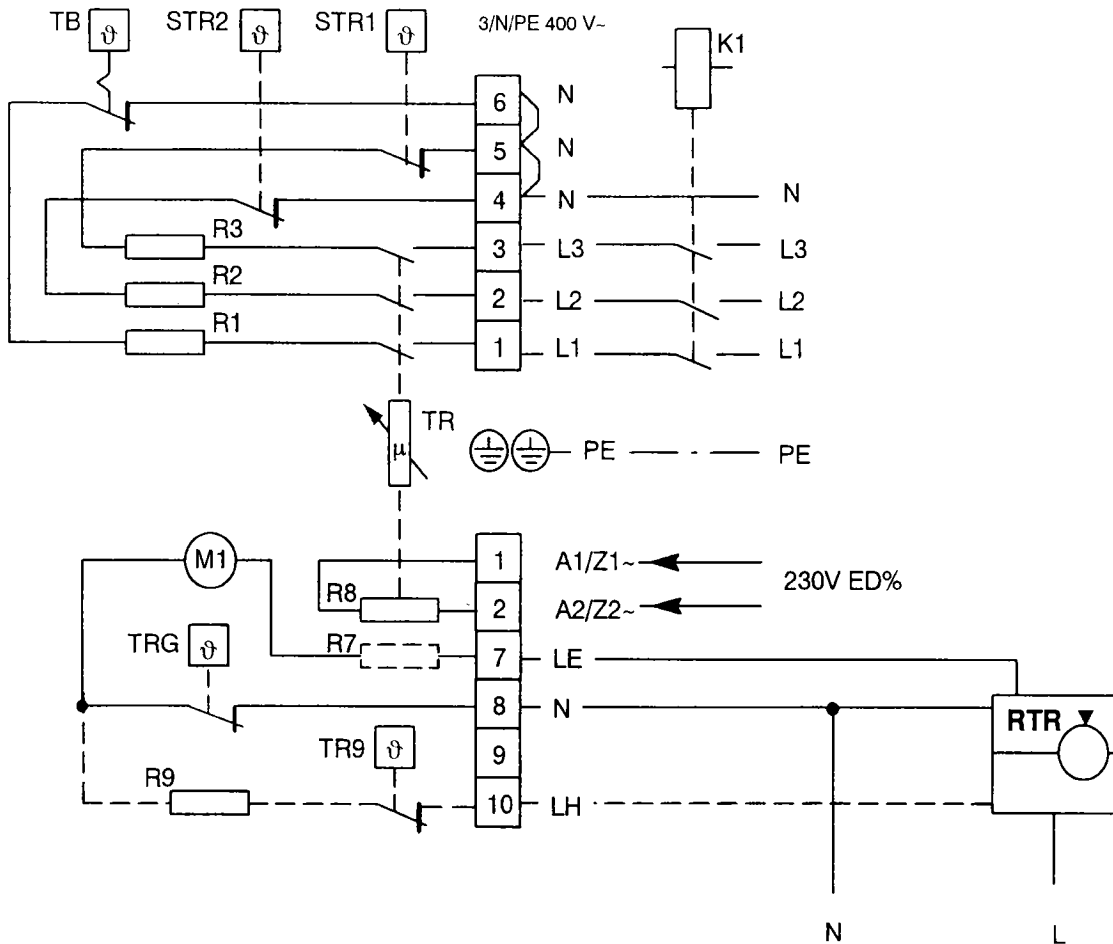

16.

Circuit diagram designations

- A1/Z1~ – Control signal of charging control (not necessary if manual charging is desired)
- A2/Z2~
- K1 – Heating contactor
- L1,L2,L3 – External conductor
- LE – Control for fan
- LH – Control for additional heating
- M1 – Fan motor
- N – PEN conductor
- PE – Protective conductor
- R1-R3 – Heating elements
- R7 – Series resistor for fan
- R8 – Control resistor
- R9 – Additional heating (accessory)
- RTR – Room temperature controller
- STR 1,2 – Safety temperature controller
- TB – Thermal cutout
- TR – Charging controller
- TR9 – Temperature control, extra heat
- TRG – Temperature control, air grille

Unit assembly

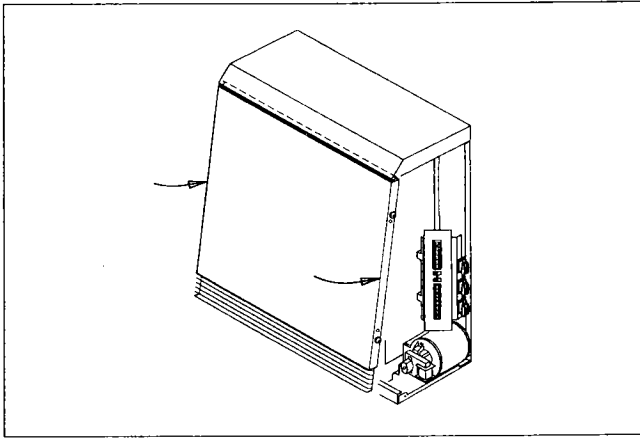

17. Insert the front wall into the folded edge on the cover, raising the cover slightly in doing so.

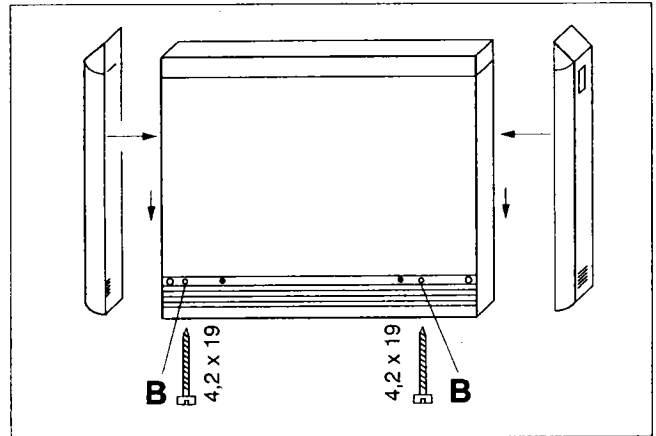

18. Screw the front wall tight (screw B).

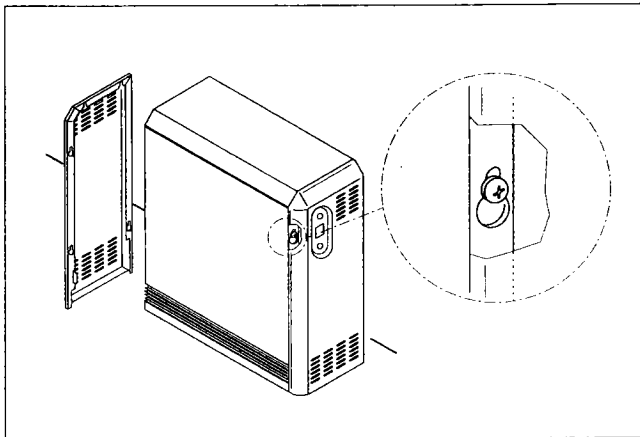

19. The side walls have keyhole-cutouts. Push the side walls over the screws and push downwards.

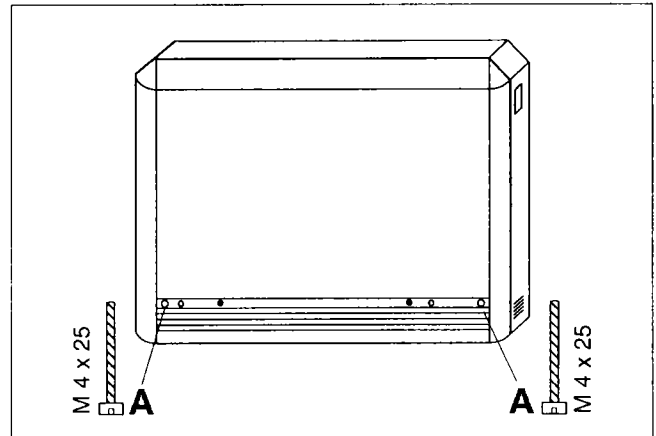

20. Screw the side walls tight. Assembly is now finished.

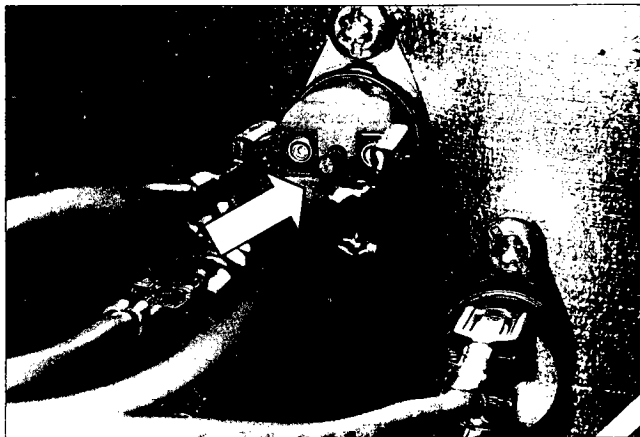

Resetting the thermal cutout (when there has been a fault):
This should only be done by a skilled person!
– Isolate the storage heater from the power supply.
– Allow the unit to cool down sufficiently.
– Remove the right-hand side panel.
– Press the reset button, e.g. using the blade of a screwdriver.

Charging control

If a central charging control is used, the control signal must be connected to terminals A1/Z1, A2/Z2 of the storage heater, see circuit diagram on page 8.

Please pay attention to the charging control notes in the operating instructions.

Commissioning

When all installation and connection work has been completed, the heater must be tested to ensure it is functioning properly.

The following minimum tests shall be performed:

Insulation test with a voltage of at least 500 V. The insulation resistance must not be less than 0.5 MΩ.

The installer shall measure the power consumption (e.g. with a kWh counter). As an alternative, a cold resistance test can be performed.

It is not necessary for a specialist to carry out initial heating-up of the unit. Once the operating test has been completed, the unit can be handed over straight away to the user for heating.

Re-installation

Units which have already been in service, dismantled and re-installed elsewhere, must be commissioned after their re-installation in accordance with the instructions stated under "Commissioning" above.

When carrying out installation, it must be ensured that the thermal insulation is not damaged. Damaged sections of the thermal insulation must be replaced.

The first charging after re-assembly, starting from cold condition of the unit (room temperature) up to switching off the charging controller, must be supervised by a specialist. The electrical power consumed shall be recorded. This must not be more than 125% of the rated charging indicated on the capacity plate.

Notes regarding repair

Repairs to electric storage heaters must only be performed by specialists. Improper repairs may involve considerable risks for the user.

The heaters are equipped with high-quality thermal insulation. Only remove the core space cover with integrated thermal insulation if radiators need to be replaced.

Access to all other electrical parts is provided by removing the side wall.

All materials of this appliance are recycabel.

Technical information

Model	Storage bricks set	Heating element	Wattage of heating elements	Mains voltage	Charge acceptance in kWh	Heater weight in kg	Transportation weight in kg	Dimensions in mm W x H x D
VFMi 20	4 x 25	HFi 212 HFi 216 HFi 220 HFi 227	1250 1600 2000 2700*	3/N/PE~ 400 V	16	98	34,5	626 x 672 x 250
VFMi 30	6 x 25	HFi 318 HFi 324 HFi 330 HFi 340	1850 2400 3000 4000*	3/N/PE~ 400 V	24	137	40	776 x 672 x 250
VFMi 40	8 x 25	HFi 425 HFi 432 HFi 440 HFi 452	2500 3200 4000 5200*	3/N/PE~ 400 V	32	176	46	926 x 672 x 250
VFMi 50	10 x 25	HFi 540 HFi 550 HFi 564	4000 5000 6400*	3/N/PE~ 400 V	40	215	52	1076 x 672 x 250
VFMi 60	12 x 25	HFi 648 HFi 660 HFi 676	4800 6000 7600*	3/N/PE~ 400 V	48	254	57,5	1226 x 672 x 250
VFMi 70	14 x 25	HFi 756 HFi 770 HFi 790	5600 7000 9000*	3/N/PE~ 400 V	56	293	63,5	1376 x 672 x 250

* only for 5 and 6 hours charge period

